

2

1

Top View

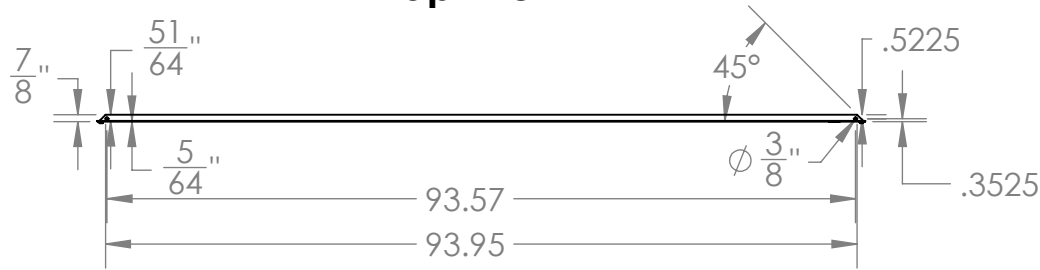

Isometric View



Front View

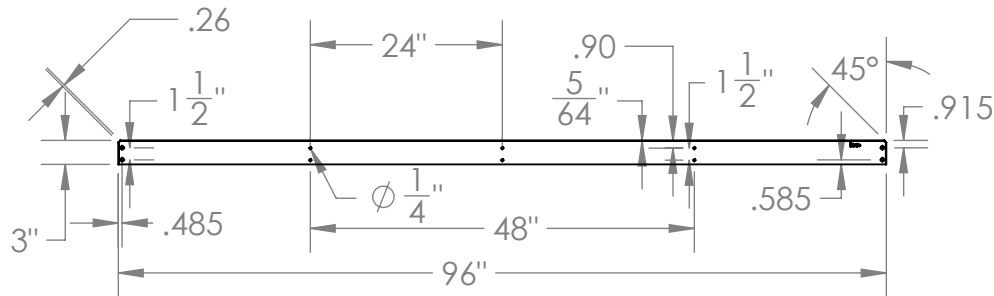

Side View

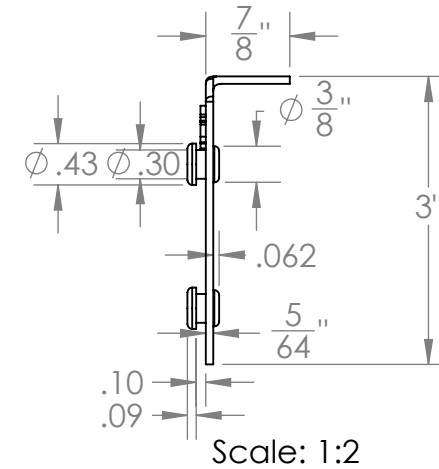

B

B

A

A

PROPRIETARY AND CONFIDENTIAL

THE INFORMATION CONTAINED IN DRAWING IS THE SOLE PROPERTY OF DIXIE SHELVING CONCEPTS. ANY REPRODUCTION IN PART OR AS A WHOLE WITHOUT THE WRITTEN PERMISSION OF DIXIE SHELVING CONCEPTS IS PROHIBITED.



UNLESS OTHERWISE SPECIFIED:

DIMENSIONS ARE IN INCHES  
TOLERANCES: ± 1/32"

MATERIAL: 14 GAUGE STEEL - 50 ksi MAX YIELD

FINISH: POWDER COATED

PART FOR ASSEMBLY OF:  
WIDESPAN STORAGE SYSTEM

COMMENTS:  
- MINIMUM 4 OF THESE TYPE OF PARTS  
NECESSARY FOR ASSEMBLY  
- FILLET RADIUS: 0.05 in.

DO NOT SCALE DRAWING

DRAWN BY: NICK LOUPE (6/14/2018)

TITLE:

Widespan:  
Two Rivet Beam - 96 in.

SIZE	DWG. NO.	REV
<b>A</b>	1	

SCALE: 1:24	WEIGHT: 7.9 LBS.	SHEET 1 OF 1
-------------	------------------	--------------

2

1