

2

1

Bottom View

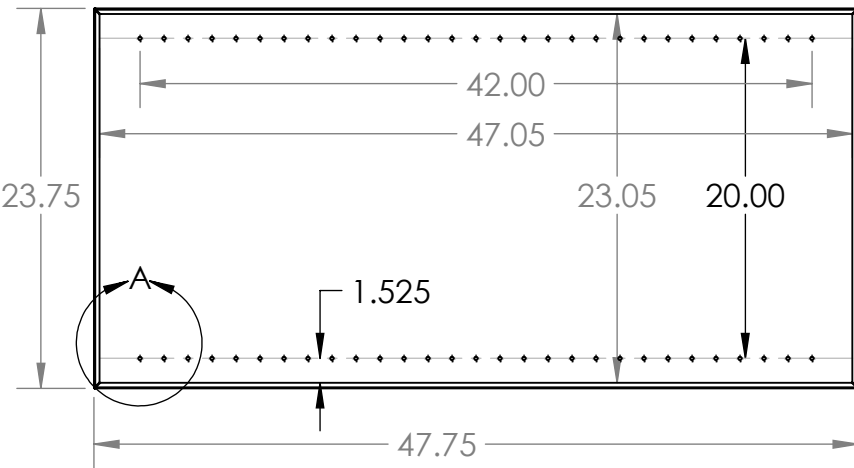

Bottom Isometric View

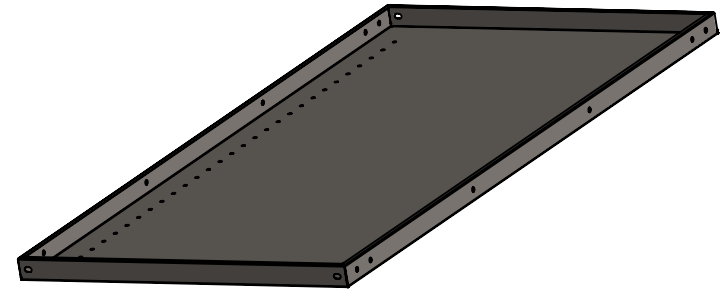

Side Views [Scale 1 : 8]

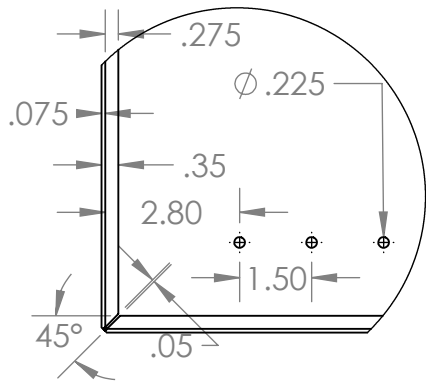

DETAIL A
SCALE 1 : 4

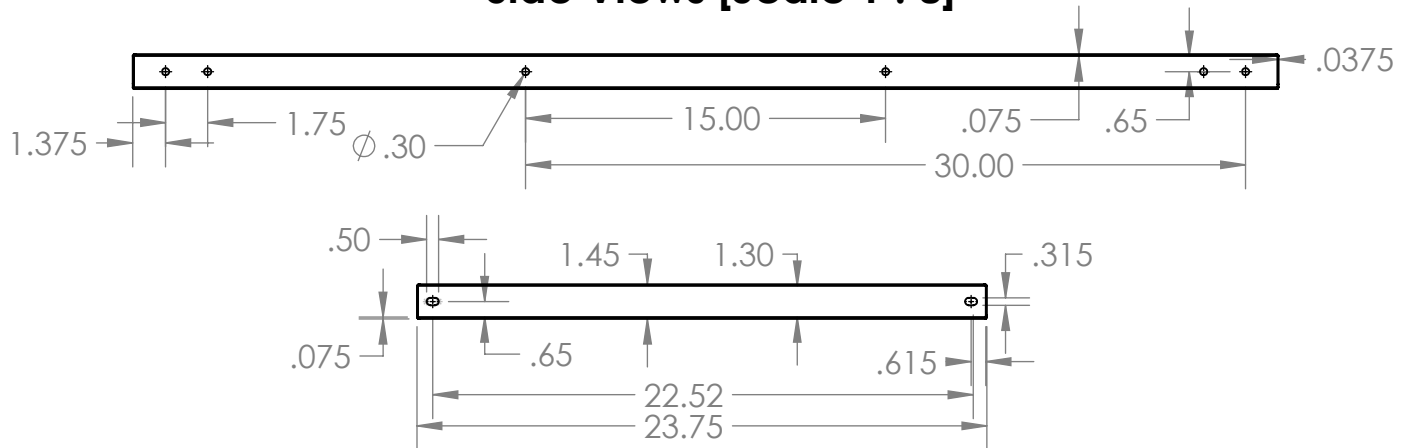

PROPRIETARY AND CONFIDENTIAL

THE INFORMATION CONTAINED IN DRAWING IS THE SOLE PROPERTY OF DIXIE SHELVING CONCEPTS. ANY REPRODUCTION IN PART OR AS A WHOLE WITHOUT THE WRITTEN PERMISSION OF DIXIE SHELVING CONCEPTS IS PROHIBITED.

UNLESS OTHERWISE SPECIFIED:

DIMENSIONS ARE IN INCHES
TOLERANCES: ± 1/32"

MATERIAL: 18 GAUGE STEEL

FINISH: POWDER COATED

PART FOR ASSEMBLY OF:
INDUSTRIAL METAL SHELVING STORAGE SYSTEM
WITH A LENGTH OF 48" AND A WIDTH OF 24"

COMMENTS: SHELVES AVAILABLE IN 5 SKEWS
(CLASS: "O", "I", "IA", & "III") WITH VARIANT
SUPPORT ATTRIBUTES AND STEEL THICKNESSES
- SHELF CLASSES ARE DEPENDENT ON USER
DEFINED LOAD NECESSITIES
- CONSULT INDUSTRIAL METAL SHELVING
PAMPHLET FOR MORE DETAILS ON LOAD
CAPABILITIES AND SHELF CLASS DIFFERENCES

DO NOT SCALE DRAWING

DRAWN BY: NICK LOUPE (7/11/2018)

TITLE:

**Industrial Metal Shelving:
Shelf - L x W = 48" x 24"**

SIZE

A

DWG. NO.

1

SCALE: 1:12 WEIGHT: 14.1 LBS. SHEET 1 OF 1



2

1

B

B

A

A