

2

1

Front View

Side View

Isometric View

B

B

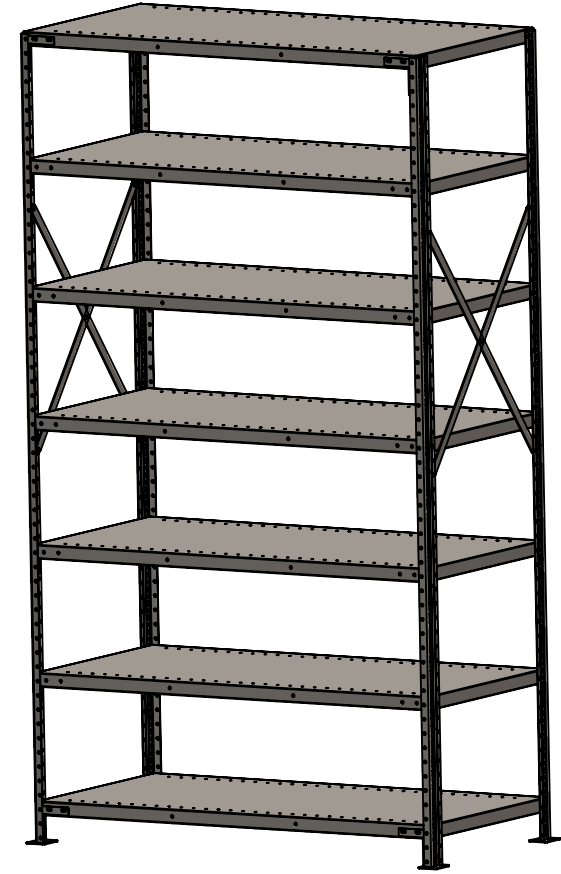
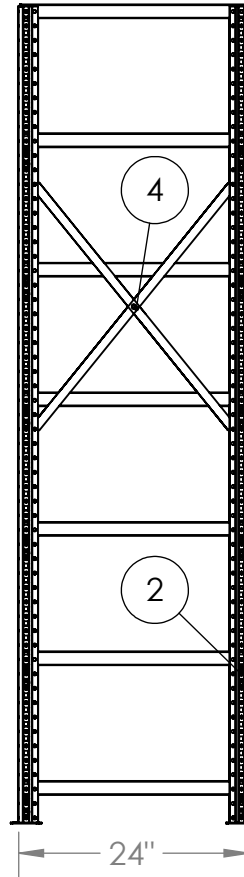
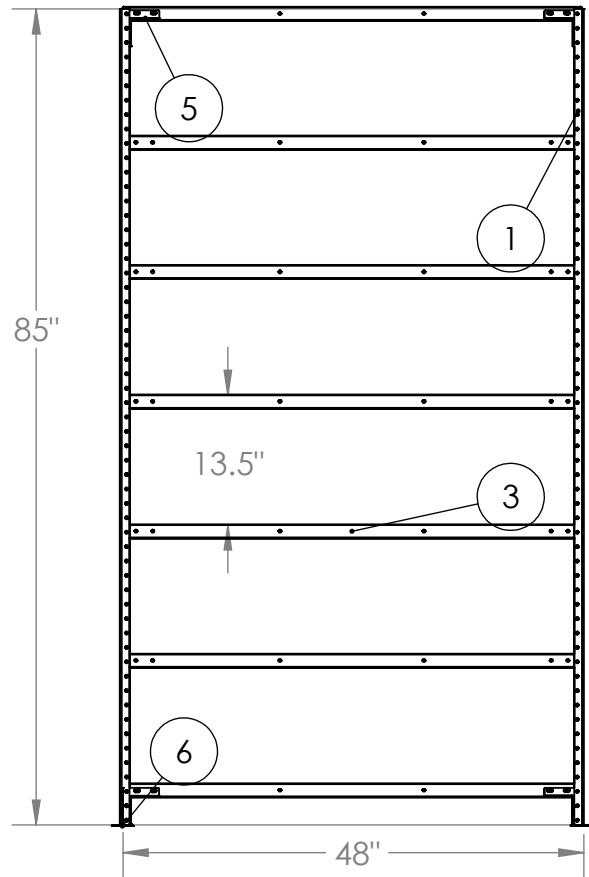

A

A

PART NO.	PART NAME	STEEL TYPE	DESCRIPTION	QTY.
1	Posts	14 Gauge	Height = 85"	4
2	Shelf Clips	12 Gauge	Stabalizes Shelves	24
3	Shelves	18 Gauge	LxW = 48" x 24"	7
4	End Braces	12 Gauge	Lateral Width = 18"	4
5	Angle Corner Bracket	12 Gauge	Adds support without the need of back braces	8
6	Foot Plates	12 Gauge	Bolts into posts and into the ground for added support	4

PROPRIETARY AND CONFIDENTIAL
 THE INFORMATION CONTAINED IN
 DRAWING IS THE SOLE
 PROPERTY OF DIXIE SHELVING
 CONCEPTS. ANY REPRODUCTION
 IN PART OR AS A WHOLE
 WITHOUT THE WRITTEN
 PERMISSION OF DIXIE SHELVING
 CONCEPTS IS PROHIBITED.



DRAWN BY: NICK LOUPE (7/12/2018)

TITLE:
**Industrial Metal Shelving:
 Open Unit Assembly:
 LxWxH = 48" x 24" x 85"**

DWG. NO.
1

COMMENTS: SHELF DIVIDERS CAN BE
 MANIPULATED TO FIT USER DESIRED ORIENTATION
 FINISH: POWDER COATED
 ASSEMBLY OF: INDUSTRIAL METAL SHELVING UNIT
 DIMENSIONS ARE IN INCHES
 TOLERANCES: ± 1/32"

SCALE: 1:20 APPROX. WEIGHT: 325 LBS.

2

1