

2

1

Front View

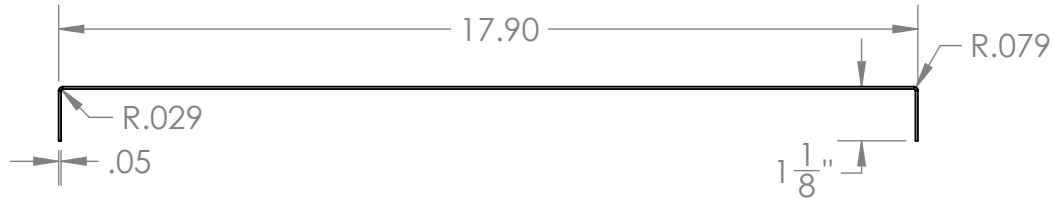

Isometric View

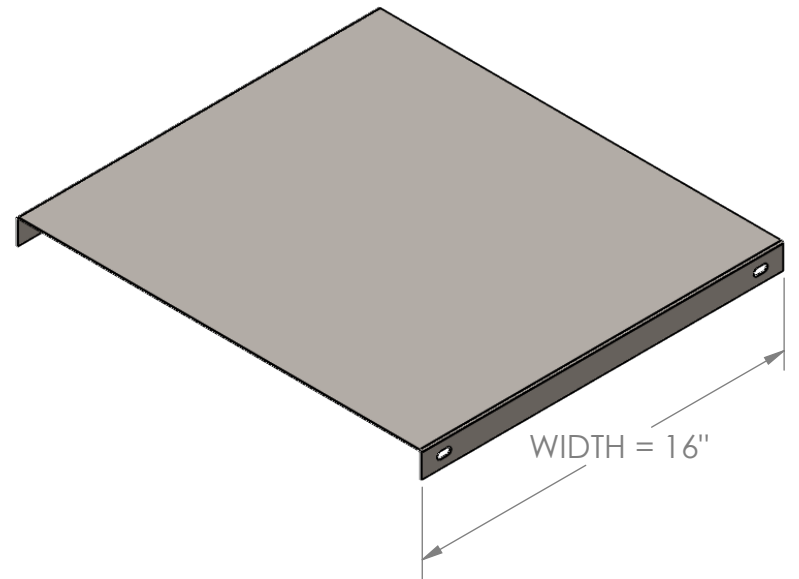

Side View

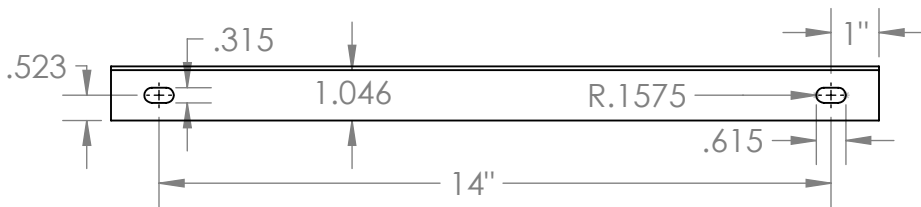

PROPRIETARY AND CONFIDENTIAL

THE INFORMATION CONTAINED IN DRAWING IS THE SOLE PROPERTY OF DIXIE SHELVING CONCEPTS. ANY REPRODUCTION IN PART OR AS A WHOLE WITHOUT THE WRITTEN PERMISSION OF DIXIE SHELVING CONCEPTS IS PROHIBITED.

UNLESS OTHERWISE SPECIFIED:

DIMENSIONS ARE IN INCHES
TOLERANCES: ± 1/32"

MATERIAL: 20 GAUGE STEEL

FINISH: POWDER COATED

PART FOR ASSEMBLY OF:
INDUSTRIAL METAL SHELVING

COMMENTS:
USED IN ASSEMBLY OF CLOSED INDUSTRIAL METAL SHELF WITH A WIDTH OF 18", A HEIGHT OF 85", AND 4 SHELF OPENINGS

DO NOT SCALE DRAWING

DRAWN BY: NICK LOUPE (6/29/2018)

TITLE:
**Industrial Metal Shelving:
Closed Unit Shelf Divider -
W x H = 16" x 18"**

SIZE
A

DWG. NO.
1

DIVIDERS SIT VERTICALLY INSIDE SHELVING UNIT, SCREW INTO TOP AND BOTTOM SHELVES IN USER DESIRED LOCATION

SCALE: 1:4 WEIGHT: 4.3 LBS. SHEET 1 OF 1

2

1

B

B

A

A

